

## ASSEMBLY INSTRUCTIONS

This table is contained in to three separate cartons:

**Carton #1** (master table carton): Contains set of aprons, set of rails, main frame, owner's manual, cloth kit also hardware kit, grout kit and cloth kit (optional).

**Carton #2:** Contains two pedestals.

**Carton #3:** Contains set of slate with slate liner.



**THE FOLLOWING STEP  
REQUIRES TWO OR MORE  
CAPABLE ADULTS**



**CAUTION**



To ensure safety, do not attempt to assemble product without following instructions carefully. Proper and complete assembly, use, and supervision are essential for proper operation and to reduce risk of accident or injury. A high probability of serious injury exists if this pool table is not installed, maintained, and operated properly.

### INSTRUCTIONS:

#### 1. Unpack master carton:

Put two side beams, two end beams and two cross beams top face down on flat floor, (**NOTE:** Top of frame identified by painted marks. Orient frame members accordingly.) Using sixteen hex head lag screws (#13) and sixteen washers (#14) attach two cross beams between two side beams. Align with pre-drilled holes and notches. Attach end beams to side beams using pre-drilled holes. **See Fig.1.**

**CAUTION! SIDE BEAMS MAY HAVE EXTRA HOLES NOT NEEDED FOR THIS TABLE ASSEMBLY, PLEASE FOLLOW INSTRUCTION CAREFULLY.**

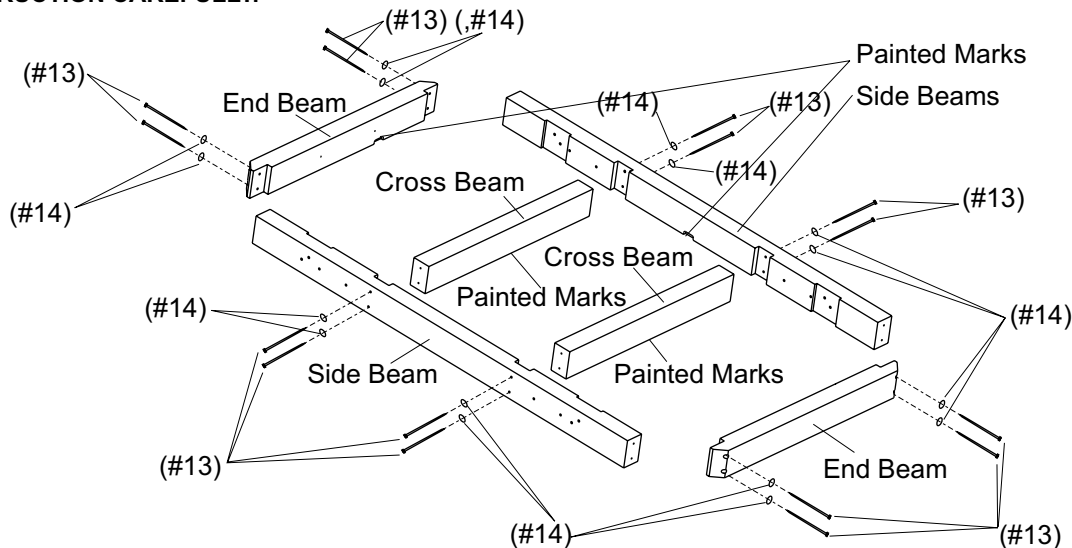

**Fig.1**

#### 2. Attach pedestals to main frame:

Keep painted marks top side of main frame face down. Flip pedestal over and align pre-drill holes on pedestal with pre-drilled hole on side beams. Attach using eight hex bolts (#9), eight split lock washers (#10), sixteen washers (#11) and eight hex nuts (#12). **See Fig.2**

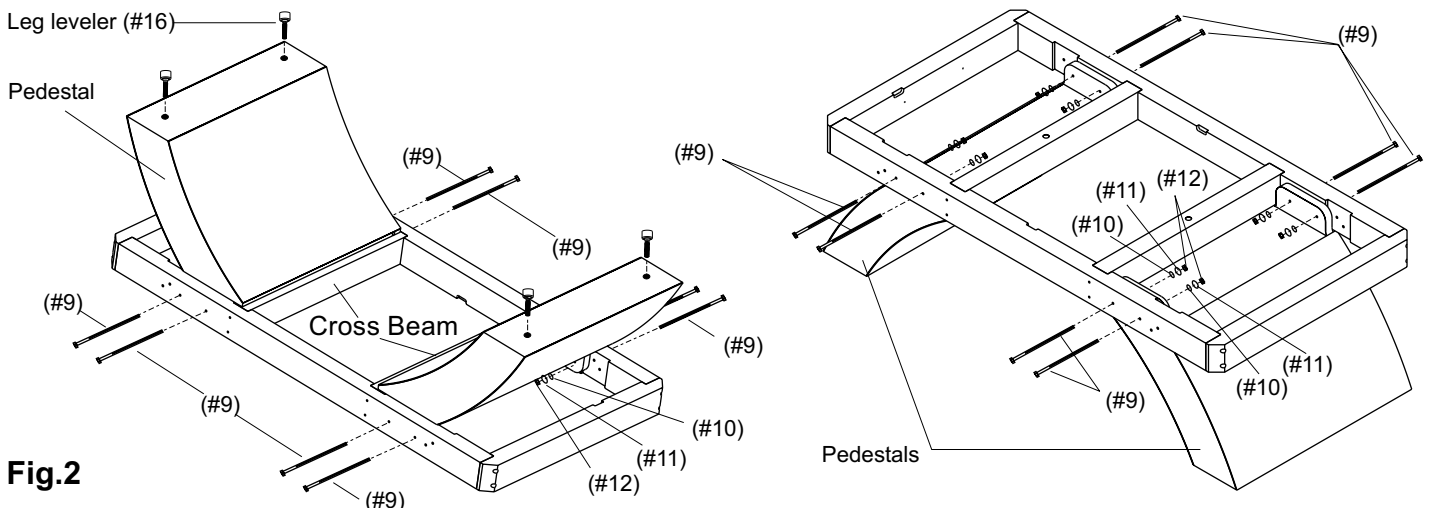

**Fig.2**

# ASSEMBLY INSTRUCTIONS

3. Rotate table carefully until it is in an upright position. Position and place table in desired location and level pool table using Carpenter's Level. Use adjustable four leg levelers (#16) to level table: turn counterclockwise to raise lower end according to bubble level. **See Fig.3.**

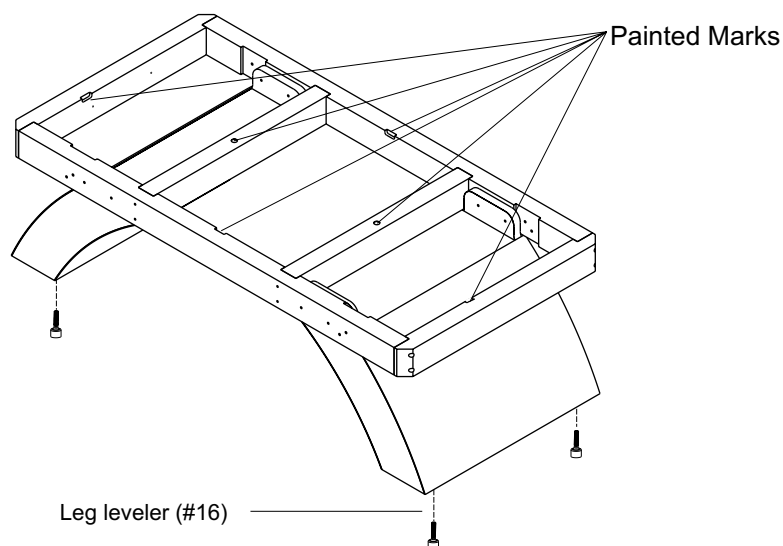

Fig.3

4. Install slate with liner on main frame:  
Unpack slate pack. **Clean slate and liner completely of dust and wood chips. Any dirt and debris will prevent center section and end sections from aligning properly.**

Position slate on top of main frame, Place center slate on center of main frame, line up end slates on each end.  
**NOTE: Be sure there are no gaps between center slate and end slates. See Fig.4 and Fig.5.**

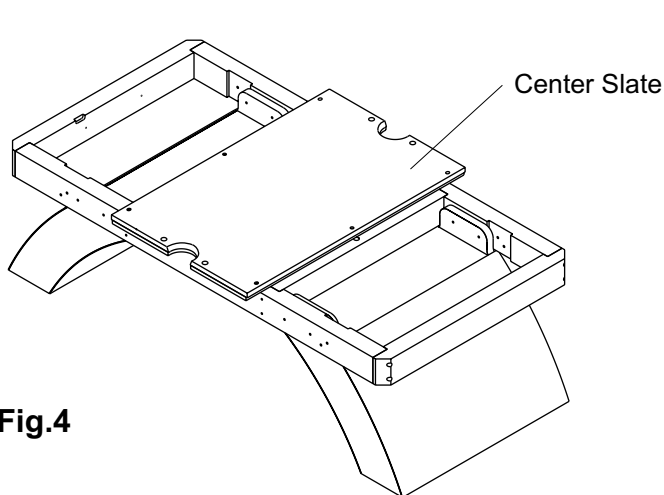

Fig.4

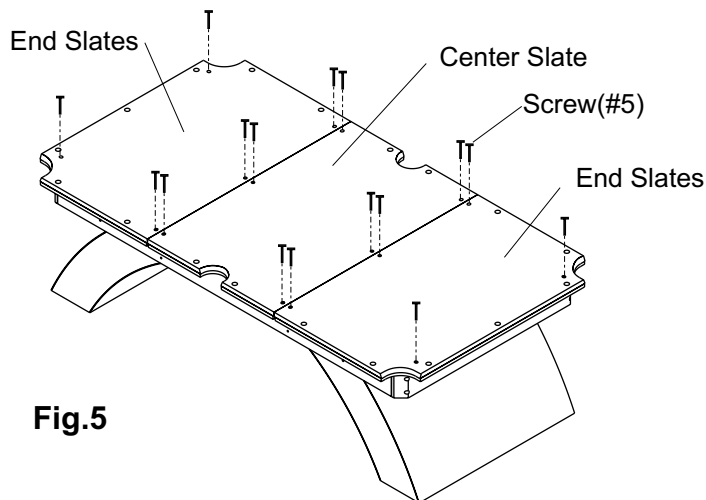

Fig.5

5. Attach slate with liner to main frame using eighteen wood screws (#5) follow by pre-drill holes on slate. **KEEP ALL SCREWS IN LOOSE POSITION, TIGHTEN ALL SCREWS AFTER SHIMMING AND GROUTING THE SLATE.**
6. Shim and Grout slates with kits provided. (See Grout Kit and Instructions below.)

## **SHIMMING INSTRUCTIONS:**

### **GENERAL RULES**

- a.) Accomplish leveling of slate with as few shims as possible.
- b.) Slate is brittle. Do not tap with a hammer or tighten screws unreasonably. Slate will not be able to compress. most shim up to level. Shims are meant only to raise the low places at the seams and ends. Do not assume the floor is level. Most leveling can be accomplished by working with frame.
- c.) If power tools are used, be sure only enough torque is used to do the job.
- d.) Seams can best be checked by passing ones finger over seam joint and feeling if it is flush.
- e.) All screws must be tightened after shimming.

**STEP-BY-STEP SHIMMING PROCEDURE**

- a.) Be sure table is set in its final location.
- b.) Table must be as level as possible before shimming. Large differences in levelness must be corrected by raising or lowering frame with shim stock. **DO NOT ASSUME FLOOR IS LEVEL!**
- c.) Tighten down all slate mounting screws.
- d.) Check with a carpenter's level to determine which slate end is level, and use finger tips to locate uneven spots at seams. Loosen screws at these points and see if slate comes up to flush. If so, detach individual shims from sheet shipped with this table and place under these areas. Place shims next to screws.
- e.) Lay a straight edge across seams to be sure slate pieces are flat in relation to each other.
- f.) After top surface of slate is flat and level, all screws must be snugged down in tight position. **DO NOT OVERTIGHTEN SCREWS! SLATE IS BRITTLE!** Check these screws before beginning grouting.

**GROUTING INSTRUCTIONS:**

- a.) Clean top of slate with damp cloth. **DO NOT USE TOO MUCH WATER!**
- b.) Prepare Plaster of Paris furnished with this table. Add water sparingly. Do not mix all the powder at first; save some in case needed to thicken initial mixture. To mix: Pour 1/3 to 1/2 of grout into container; slowly add drops of water while stirring. Grout should be a thick paste when mixed (will not drip off putty knife). If grout is too thin, slowly add more powder.
- c.) Using a putty knife fills both seams and the four countersunk holes in the center playfield area. (Only the countersunk holes in center of table need to be filled since rails will cover other holes.) Do not use more plaster than necessary.
- d.) Let plaster dry. Read the rest of this manual while waiting!
- e.) Using medium grit sandpaper and sanding block, sand plastered areas smooth and flat. **RECHECK THESE AREAS TO MAKE SURE THEY ARE FLAT.** Re-plaster if low places are found at countersunk holes or seams.

- 7. Cloth bed and cushions. Attach with staples or tacks as required. **See "Murrey bed and cushion clothing instructions" inside cloth kit.**
- 8. Complete rail assembly, mount two center castings and four corner castings using twelve Hex bolts (#1), twelve split lock washers (#2), twelve std.(#3) washers and twelve square nuts (#4) and using twelve screws (#19) for additional support. **See Fig.6 For details.**
- 9. Complete aprons assembly. Using sixteen wood screws (#7) and four corner posts (#17) attach two side aprons and two end aprons and attach aprons to rails using twelve 85 degree brackets (#8) with thirty-six screws (#7). **See Fig.7**

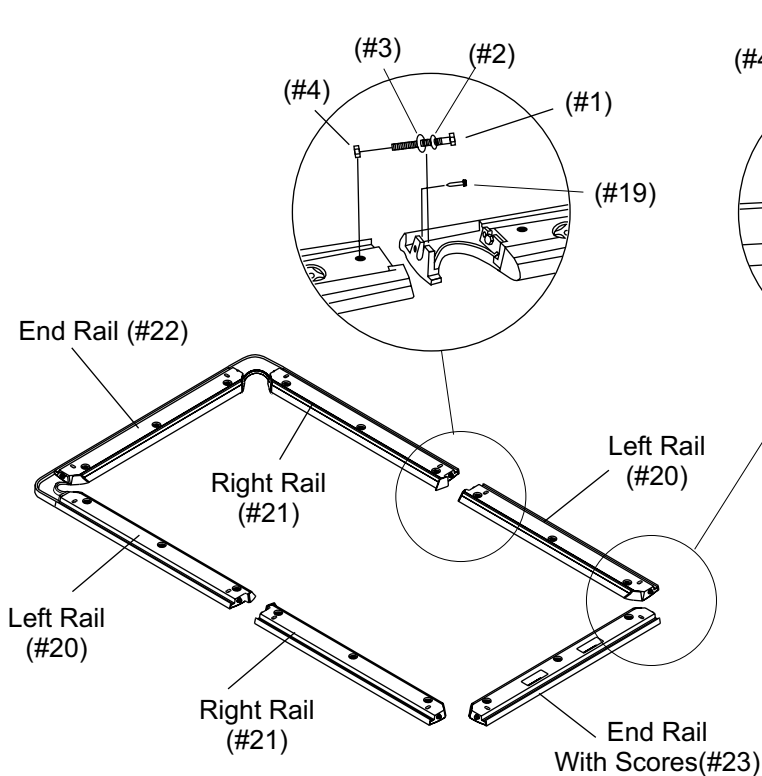

**Fig.6**

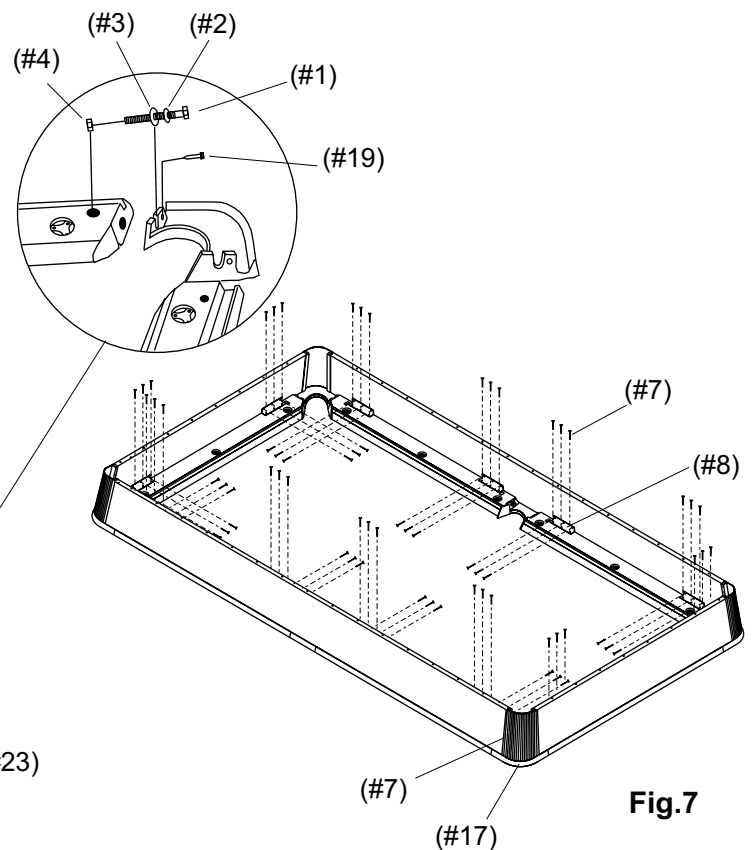

**Fig.7**

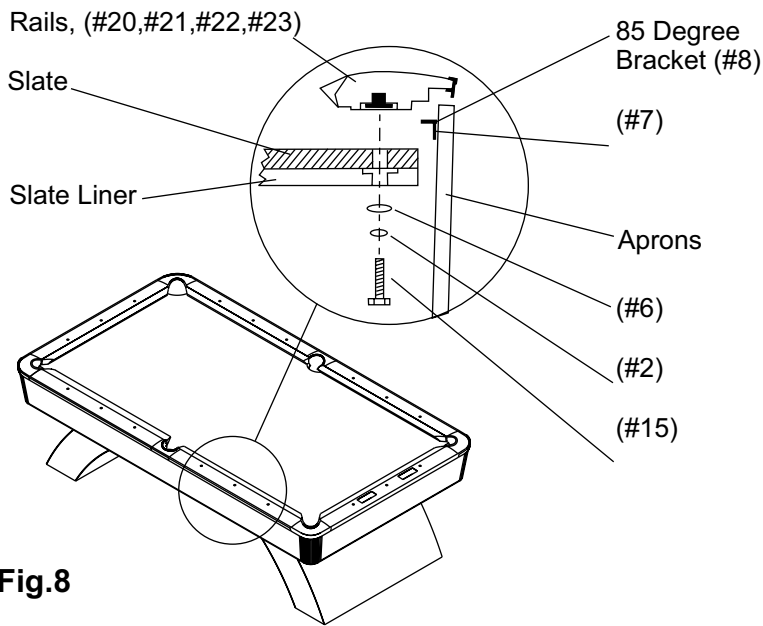

10. Attach rail assembly and apron assembly using Thirty-six wood screws (#7) and twelve 85 degree brackets (#8) See Fig.7 and Fig.8.

11. Using eighteen flat washers (#6), eighteen lock washers (#2), and eighteen hex head bolts (#15), attach rails to slate and slate liner. See Fig.8

Measure play area. Left and right rail assemblies and end rails should be parallel and perpendicular to each other, respectively.

Fig.8

## HARDWARE IDENTIFIER

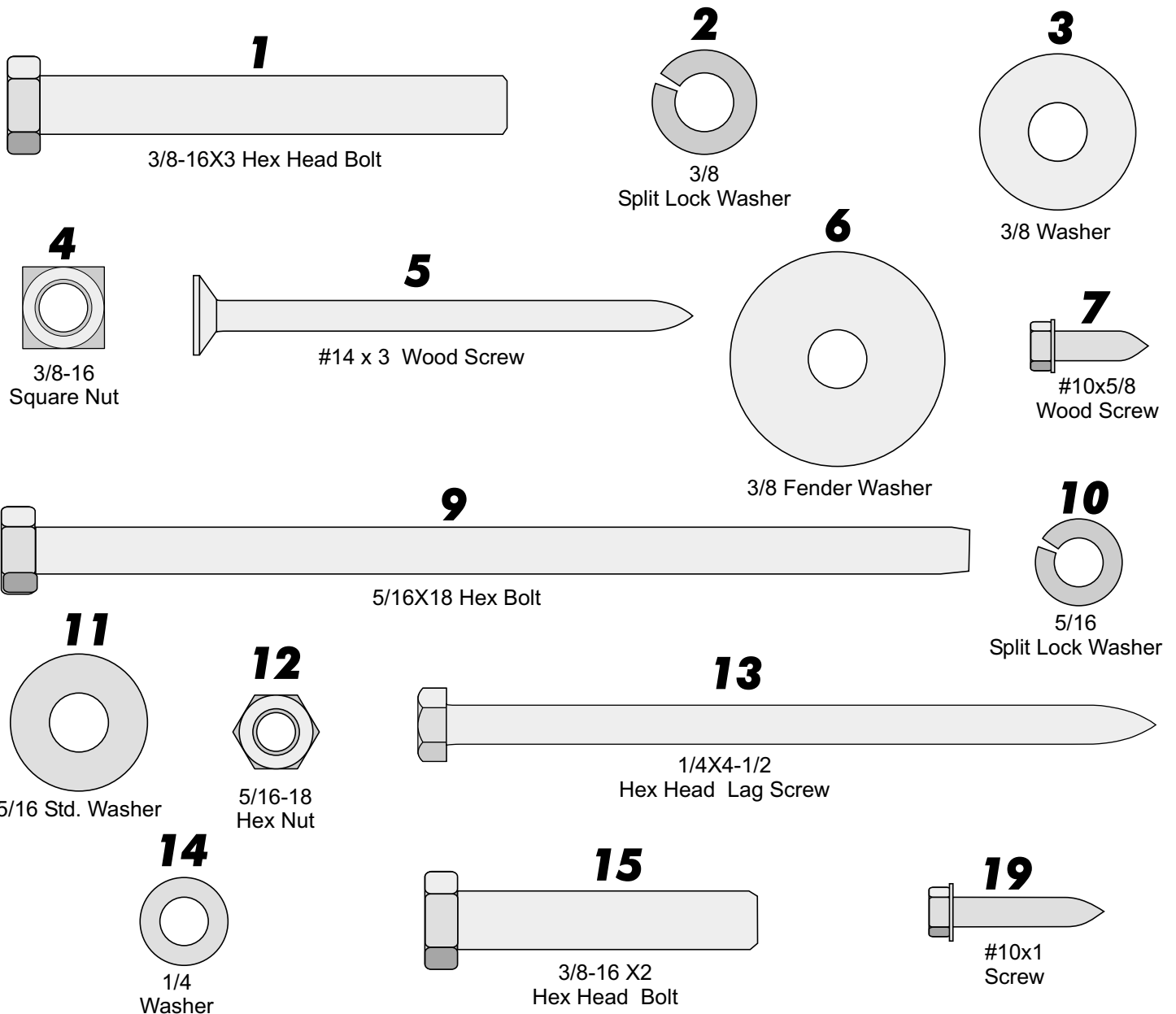

# PRODUCT PARTS LIST

Model Number: P3225, P3225A, P3226, P3226A

ITEM#	PART#	DESCRIPTION	QTY	ITEM#	PART#	DESCRIPTION	QTY
1	1B-6558-00	3/8-16X3 HEX HEAD BOLT	12	13	1B-6566-00	1/4 X4-1/2 HEX HEAD LAG SCREW	16
2	901-69	3/8 SPLIT LOCK WASHER	30	14	2B-6133-00	1/4 WASHER	16
3	701-50	3/8 WASHER	12	15	1B-6554-00	3/8-16X2 HEX HEAD BOLT	18
4	1B-6496-00	3/8-16 SQUARE NUT	12	16	2Q-6417-00	LEG LEVELER	4
5	1B-6573-00	#14X3 SCREW	18	17	2C-6344-00	CORNER POST	4
6	2B-6138-00	3/8X1-3/8 FENDER WASHER	18	18	4B-6034-00	POCKET NAIL	34
7	1B-6518-00	#10 5/8 SCREWS	68	19	1B-6556-00	#10x1 SCREW	12
8	2S-6475-00	85 DEGREE BRACKET	12	20	2A-6853-00	LEFT RAIL	2
9	1B-6519-00	5/16X18 HEX BOLT	8	21	2A-6854-00	RIGHT RAIL	2
10	2B-6023-00	5/16 SPLIT LOCK WASHER	8	22	2A-6855-00	END RAIL	1
11	2B-6024-00	5/16 WASHER	16	23	2A-6856-00	END RAIL W/SCORES	1
12	2B-6025-00	5/16-18 HEX NUT	8	24	2L-6763-01	THIS MANUAL	1

## MURREY PRODUCTS TWO YEAR LIMITED WARRANTY

**WARRANTY DURATION:** This Murrey billiard table is warranted to the original consumer purchase for a period of 2 years against workmanship defects in the cabinet. It also warrants a period of 90 days against workmanship defects in the cloth, rubber and pockets from the original purchase.

**WARRANTY COVERAGE:** ESCALADE SPORTS warrants to the original Consumer Purchaser that any Product of its manufacture is free from defects in material and workmanship when used for the intended purpose under normal use and conditions.

THIS WARRANTY IS VOID IF THE PRODUCT HAS BEEN DAMAGED BY ACCIDENT, UNREASONABLE USE, NEGLIGENCE, IMPROPER SERVICE, FAILURE TO FOLLOW INSTRUCTIONS PROVIDED WITH THE PRODUCT OR OTHER CAUSES NOT ARISING OUT OF DEFECTS IN MATERIAL AND WORKMANSHIP.

**WARRANTY PERFORMANCE:** During the above warranty period, ESCALADE SPORTS shall repair or replace with a comparable model, and/or product, or component thereof, for any product which may prove defective under normal use, proper care and which our examination shall disclose to our satisfaction to be thus defective, please contact our Warranty Dept.

1-866-556-2757 / Warranty Dept.

Or Write us at:

Escalade® Sports, Inc. - P. O. Box 889, Evansville, IN 47706 - Attn: Warranty Dept.

Or E-mail us at:

billiardtables@escaladesports.com

Other than shipping requirements no charge will be made for such repair or replacement of in-warranty Products. ESCALADE® SPORTS strongly recommends that the Product is insured for value prior to mailing.

### WARRANTY ON SLATE SURFACE

Manufacturer warrants for ten (10) years, Escalade Sports will repair the playing surface of this table, free of charge, if it fails to remain flat, within a tolerance of + or - 30/1000 of an inch, measuring from any flat plane within the playing surface. **NOTE:** Cloth not included in warranty. Should this product become defective due to material or workmanship within period, contact the Customer Service Department. This warranty is not transferable and does not cover normal wear and tear, or damage caused by improper handling, installation or use of this product. This warranty is also void if product is in any way abused, damaged, or modified from its original state, or if used for other than indoor residential use. This warranty gives the consumer specific legal rights, and may have other rights which may vary from state to state.

**WARRANTY DISCLAIMERS:** ANY IMPLIED WARRANTIES ARISING OUT OF THIS SALE, INCLUDING BUT NOT LIMITED TO THE IMPLIED WARRANTIES OF MERCHANTABILITY AND FITNESS FOR A PARTICULAR PURPOSE, ARE LIMITED IN DURATION TO THE ABOVE WARRANTY PERIOD. ESCALADE® SPORTS SHALL NOT BE LIABLE FOR LOSS OF USE OF THE PRODUCT OR OTHER CONSEQUENTIAL OR INCIDENTAL COSTS, EXPENSES OR DAMAGES INCURRED BY THE CONSUMER OF ANY OTHER USE.

Some states do not allow the exclusion or limitation of implied warranties or consequential or incidental damages, so the above limitations or exclusions may not apply to you.

**LEGAL REMEDIES:** This warranty gives you specific legal rights and you may also have other rights, which may vary, from state to state.



Mailing Address:

Escalade Sports  
P O Box 889  
Evansville, IN 47706

Phone: 1-866-556-2757 (Toll Free)

Fax: 1-866-873-3532 (Toll Free)

E-mail: billiardtables@escaladesports.com

www.escaladesports.com

www.billiardtables.com