

ASSEMBLY INSTRUCTIONS

Rail Assembly

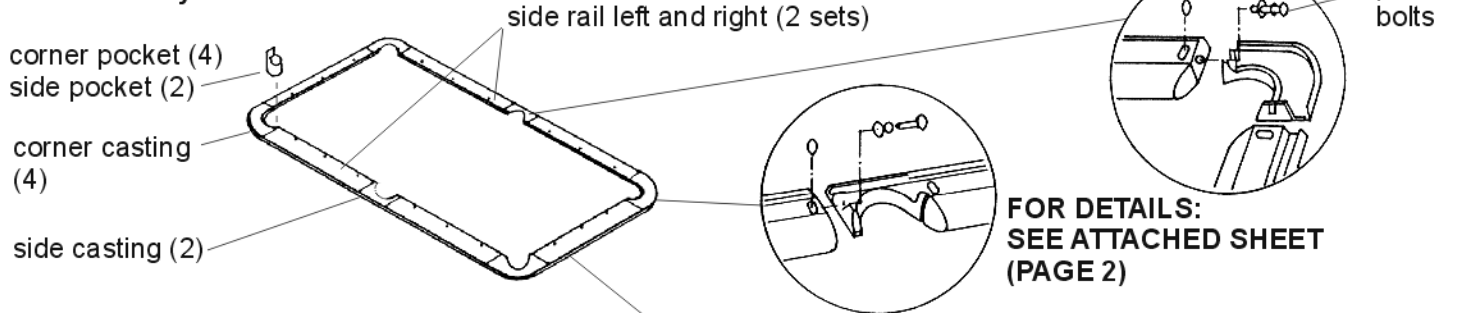

Slate Assembly

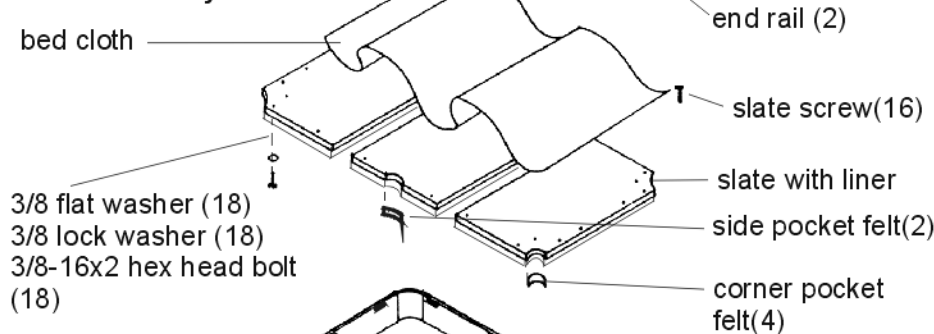

Apron Assembly

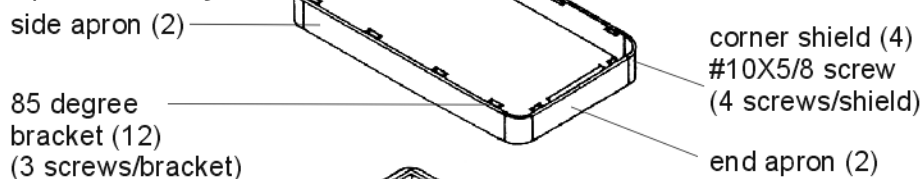

Frame Assembly

FOR DETAILS: SEE ATTACHED SHEET (PAGE 3)



Leg Assembly



INSTRUCTIONS:

- 1) ASSEMBLE MAIN FRAME.
NOTE: Top of frame identified with painted marks. Orient frame members Accordingly.
- 2) ASSEMBLE PEDESTAL LEGS TO THE SPREADER BAR AND ATTACH TO MAIN FRAME.
- 3) INSTALL SLATE ON MAIN FRAME.
- 4) LEVEL THE TABLE AS NEEDED.
- 5) CLOTH BED.
- 6) INSTALL CORNER AND SIDE POCKET FELT.
- 7) CLOTH RAILS AND MOUNT TO CASTINGS.
- 8) MOUNT RAIL CASTING ASSEMBLY TO TABLE.
- 9) ATTACH APRON ASSEMBLY.
- 10) INSTALL BRIDGE AND TRIANGLE HOLDER.

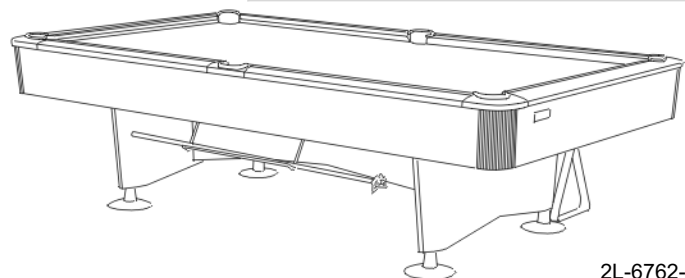

2L-6762-01 PAGE 2

RAIL CASTING ASSEMBLY

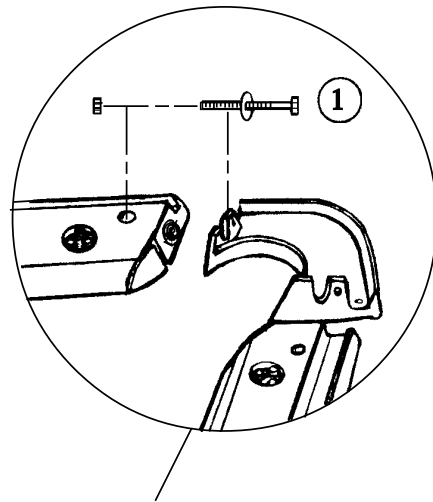
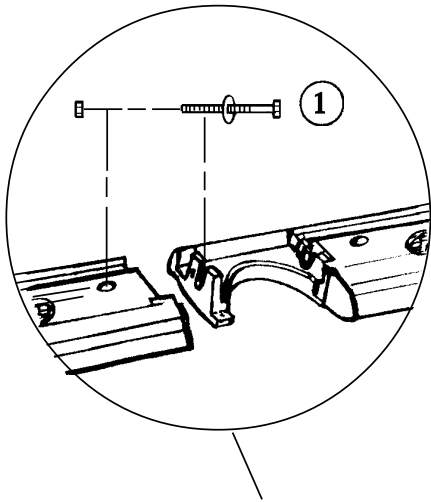

1. Adjust and Secure Castings as Required.

2. Install 1-1/2" Wood Screws for Additional Support.

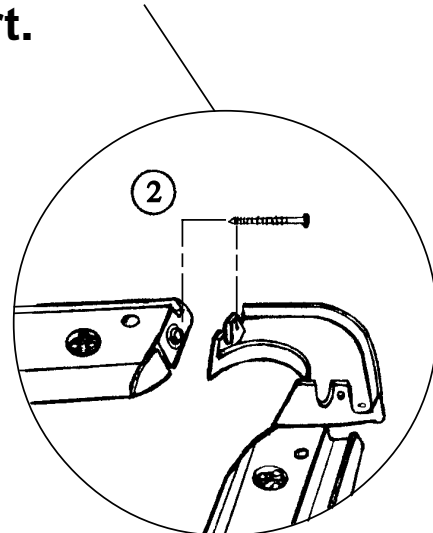
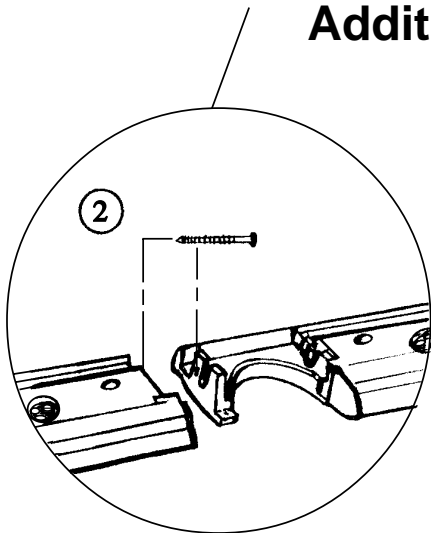

2L-6762-01 PAGE 2

MAIN FRAME ASSEMBLY

1) Assemble two pedestals to spreader bar, insert leg levelers.

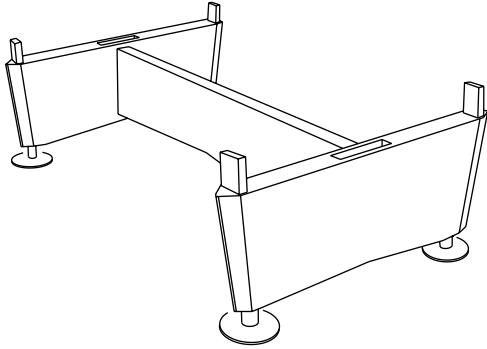

2) Place side beam on outside of pedestals (2 bolts in 4 places) and attach loosely as shown.
Note: Top of frame marked with white notch. Orient frame members accordingly.

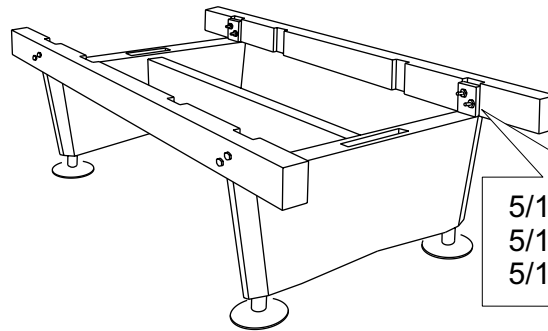

5/16-18x5 hex bolt (8)
 5/16 std. washer (16)
 5/16-8 hex nut (8)

3) Insert cross beam into notches on side beams and attach loosely as shown.

4) Attach end beams to ends of frame sides loosely as shown.

5) Square beams to one another and tighten all beam bolts and leg mounting bolts. Level frame using leg levelers.

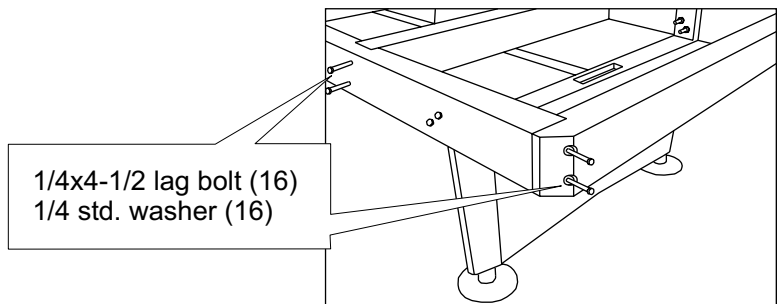

1/4x4-1/2 lag bolt (16)
 1/4 std. washer (16)

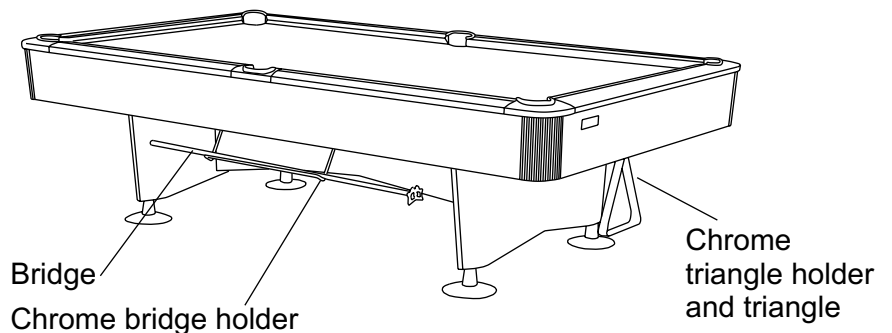
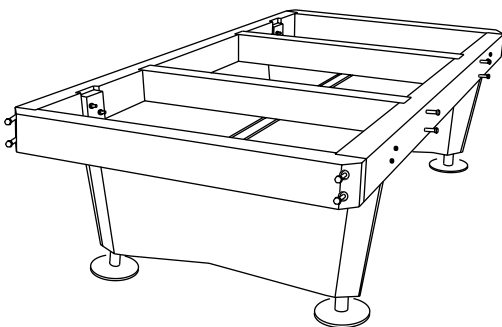

MURREY PRODUCTS ONE YEAR LIMITED WARRANTY

WARRANTY DURATION: This Murrey billiard table is warranted to the original consumer purchase for a period of 1 year against workmanship defects in the cabinet. It also warrants a period of 90 days against workmanship defects in the cloth, rubber and pockets from the original purchase.

WARRANTY COVERAGE: ESCALADE SPORTS warrants to the original Consumer Purchaser that any Product of its manufacture is free from defects in material and workmanship when used for the intended purpose under normal use and conditions.

THIS WARRANTY IS VOID IF THE PRODUCT HAS BEEN DAMAGED BY ACCIDENT, UNREASONABLE USE, NEGLIGENCE, IMPROPER SERVICE, FAILURE TO FOLLOW INSTRUCTIONS PROVIDED WITH THE PRODUCT OR OTHER CAUSES NOT ARISING OUT OF DEFECTS IN MATERIAL AND WORKMANSHIP.

WARRANTY PERFORMANCE: During the above warranty period, ESCALADE SPORTS shall repair or replace with a comparable model, and/or product, or component thereof, for any product which may prove defective under normal use, proper care and which our examination shall disclose to our satisfaction to be thus defective, please contact our Warranty Dept.

1-866-556-2757 / Warranty Dept.

Or Write us at:

Escalade® Sports, Inc. - P. O. Box 889, Evansville, IN 47706 - Attn: Warranty Dept.

Or E-mail us at:

billiardtables@escaladesports.com

Other than shipping requirements no charge will be made for such repair or replacement of in-warranty Products. ESCALADE® SPORTS strongly recommends that the Product is insured for value prior to mailing.

WARRANTY ON SLATE SURFACE

Manufacturer warrants for ten (10) years, Escalade Sports will repair the playing surface of this table, free of charge, if it fails to remain flat, within a tolerance of + or - 30/1000 of an inch, measuring from any flat plane within the playing surface. **NOTE:** Cloth not included in warranty. Should this product become defective due to material or workmanship within period, contact the Customer Service Department. This warranty is not transferable and does not cover normal wear and tear, or damage caused by improper handling, installation or use of this product. This warranty is also void if product is in any way abused, damaged, or modified from its original state, or if used for other than indoor residential use. This warranty gives the consumer specific legal rights, and may have other rights which may vary from state to state.

WARRANTY DISCLAIMERS: ANY IMPLIED WARRANTIES ARISING OUT OF THIS SALE, INCLUDING BUT NOT LIMITED TO THE IMPLIED WARRANTIES OF MERCHANTABILITY AND FITNESS FOR A PARTICULAR PURPOSE, ARE LIMITED IN DURATION TO THE ABOVE WARRANTY PERIOD. ESCALADE® SPORTS SHALL NOT BE LIABLE FOR LOSS OF USE OF THE PRODUCT OR OTHER CONSEQUENTIAL OR INCIDENTAL COSTS, EXPENSES OR DAMAGES INCURRED BY THE CONSUMER OF ANY OTHER USE.

Some states do not allow the exclusion or limitation of implied warranties or consequential or incidental damages, so the above limitations or exclusions may not apply to you.

LEGAL REMEDIES: This warranty gives you specific legal rights and you may also have other rights, which may vary, from state to state.

2L-6762-01 PAGE 4

ESCALADE®
SPORTS

Mailing Address:
Escalade Sports
P O Box 889
Evansville, IN 47706

Phone: **1-866-556-2757** (Toll Free)
Fax: **1-866-873-3532** (Toll Free)
E-mail: **billiardtables@escaladesports.com**
www.escaladesports.com
www.billiardtables.com