

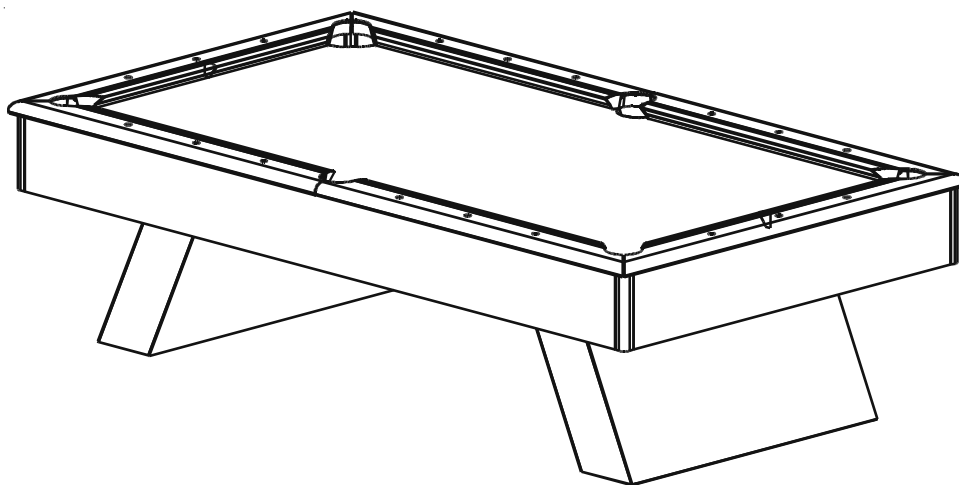

OWNER'S MANUAL

OUTDOOR 3000 BILLIARD TABLE
MODEL NO. P3251A
MODEL NO. P3257A



IMPORTANT! - COVER YOUR TABLE WHEN NOT IN USE.

This billiard table has been manufactured using special composites designed and engineered to withstand outdoor exposure including rain, sun, and wind. A **FREE** high quality exterior vinyl cover has been included with this table to keep rain and moisture off the table top playing surface.

When not in use, you should always put the vinyl form fitted cover and the foam inserts over the table top. This will dramatically extend the life of this product and keep it looking new for years to come.

The vinyl cover and foam inserts **must always be used** in rainy or stormy conditions to keep large volumes of water away from the playfield. **Failure to use the outdoor cover and foam inserts provided will result in your warranty becoming invalid.**

This table has NOT been designed for extreme weather conditions such as snow, ice and sleet. The table should be stored for winter in such extreme conditions.

PLEASE DO NOT RETURN PRODUCT TO THE STORE!

Contact Escalade® Sports Customer Service Department at:

Phone: 1-866-556-2757 Toll Free!

Fax: 1-866-873-3532 Toll Free!

E-mail: billiardtables@escaladesports.com

Mailing Address: Escalade® Sports, PO Box 889, Evansville, IN 47706

Please visit our World Wide Web site at:

www.escaladesports.com

On-Line Trouble Shooting Technical Assistance

On-Line Parts Requests Frequently Asked Questions

Additional Escalade® Sports Product Information

ESCALADE[®]
SPORTS

⚠ CAUTION ⚠

To ensure safety, do not attempt to assemble product without following instructions carefully. Proper and complete assembly, use, and supervision is essential for proper operation and to reduce the risk of accident or injury. A high probability of serious injury exists if this system is not installed, maintained, and operated properly.

NOTE: Rails are made with cushion rubber at a height that requires standard 2 1/4" diameter balls. Billiard Accessories included in this unit.

NOTE: This table adds weight to any floor. Be sure floor can withstand this kind of weight. If floor sags, table will be impossible to level.

HARDWARE IDENTIFIER: (To attach legs only)

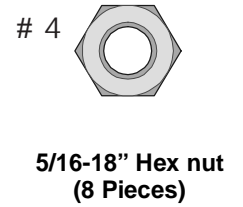
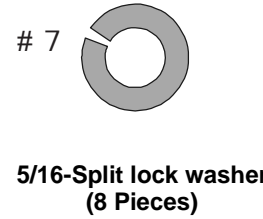
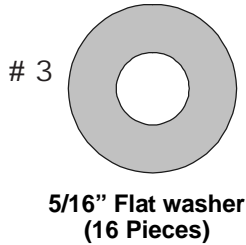

Tools Needed: (Not Included)

- 1/2" Open End Wrench
- Ratchet with 1/2" socket
- Carpenters Level

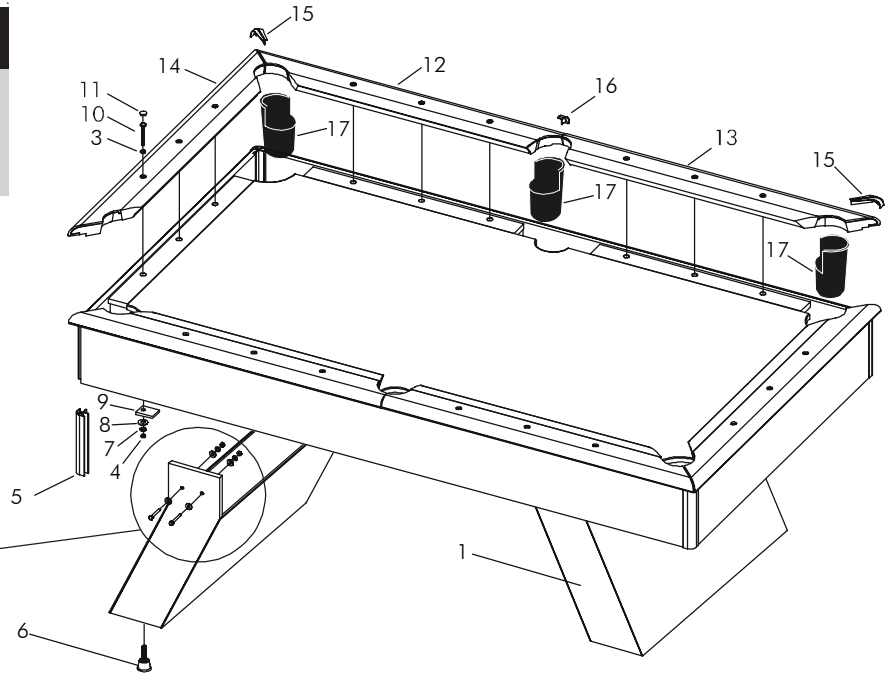
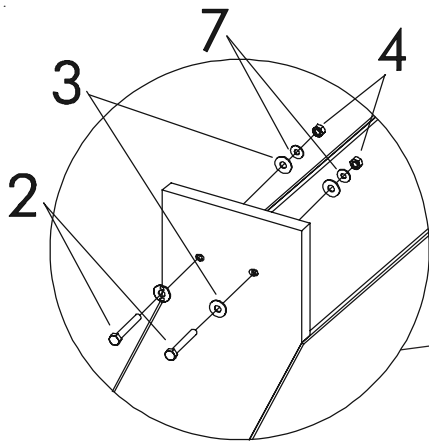

REPLACEMENT PARTS LIST

| ITEM# | PART# | DESCRIPTION | QTY | ITEM# | PART# | DESCRIPTIONS | QTY |
|-------|------------|---------------------------|-----|-------|------------|--------------------------------|-----|
| 1 | 2A-6642-00 | FINISHED PEDESTAL | 2 | 12 | 2A-6985-00 | LEFT RAIL | 2 |
| 2 | 801-66 | 5/16-18 X 2-1/4" HEX BOLT | 8 | 13 | 2A-6986-00 | RIGHT RAIL | 2 |
| 3 | 2B-6024-00 | 5/16 FLATWASHER | 34 | 14 | 2A-6987-00 | END RAIL | 2 |
| 4 | 2B-6025-00 | 5/16-18 HEX NUT | 26 | 15 | 3M-6612-00 | CORNER CAP | 4 |
| 5 | 2M-6245-00 | CORNER POST | 4 | 16 | 3M-6610-00 | SIDE CAP | 2 |
| 6 | 2Q-6417-00 | LEG LEVELER | 4 | 17 | 3M-6194-00 | DROP POCKET (SET OF 6) | 1 |
| 7 | 2B-6023-00 | 5/16 SPLIT LOCKWASHER | 26 | 18 | 3F-6036-00 | TABLE COVER | 1 |
| 8 | 2B-6058-00 | FENDER WASHER | 18 | 19 | 2L-6743-03 | THIS MANUAL | 1 |
| 9 | 2W-6759-00 | SLATE SUPPORT | 18 | 20 | 5A-6973-00 | BILLIARD ACCESSORIES KIT (SET) | 1 |
| 10 | 1B-6610-00 | 5/16-18 X 13-1/4 HEX BOLT | 18 | | | | |
| 11 | 3M-6603-00 | SIGHT PLUG | 18 | | | | |

This Table is contained in two separate containers:

- Container #1.....Contains top section of table and owner's manual.
Container #2.....Contains two pedestal assemblies and hardware kit.



1. READ THIS MANUAL CAREFULLY BEFORE STARTING ASSEMBLY

Read each step completely before beginning each step.

2. SOME SMALLER PARTS MAYBE SHIPPED INSIDE LARGER PARTS. CHECK ALL CARTONS FOR KITS.



**3. USE THE HARDWARE IDENTIFIER TO IDENTIFY AND SORT ALL FASTENERS. (See Page 2).
CHECK ALL CARTONS FOR KITS.**

Attach Legs

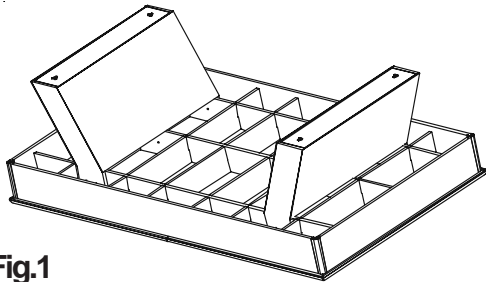

Fig.1

Bolt the pedestals to the frame using the bolts, washers, and nuts provided. Be sure to tighten securely

1. Place large master (main) table carton on floor and remove topside of box from master carton. With bottom carton flat on floor, unpack pedestals carton and position pedestals on table frame as shown in **Fig.1**.

Align bolt holes and attach pedestals using (8)Hex Bolts #2, (16)Flat washers #3, (8)Hex Nuts #4, (8)Split Lock washers #7. **(See page 2 for details)**

Rotate Over Into Upright Position



2. After securing the pedestals to the frame, you will need to get at least 4 capable adults to help.

Rotate billiard table carefully onto its side while still protected by the shipping carton. See **Fig.2**.

This table weighs approximately 650 lbs when fully assembled. Proceed slowly and continue to rotate pool table until it is in an upright position as pictured in **Fig.3**.

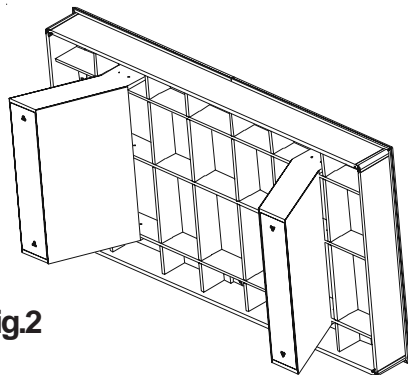

Fig.2

BE SURE TO SAVE THE 4 FOAM PIECES UNDER THE TABLE COVER. YOU WILL BE USING THESE WITH YOUR TABLE COVER.

The foam pieces are used when the table is covered to serve as a Buffet Table. The foam levels the surface under the table cover.

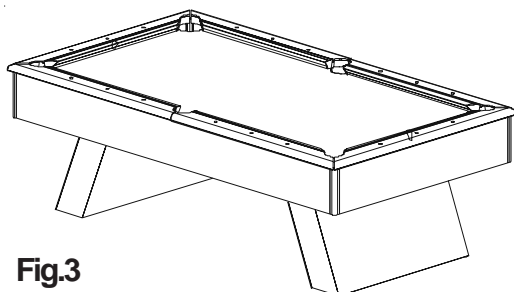

Fig.3



IT IS ALSO NECESSARY TO ALWAYS COVER THE TABLE WITH FOAM PIECES INSTALLED SO WATER WILL NOT GATHER AND POOL ON THE VINYL TABLE TOP DURING RAIN.

4. Position and place the table in the exact spot you want it and level using Carpenters Level.

Use the adjustable leg levelers to precisely level your new table by turning them counter clockwise to raise the end that is low according to your bubble level. The closer the bubble is to center, the more level your table will be. Please read and follow the instructions regarding the proper care of your new table attached to this set up guide.

5. Your table includes 1 set of regulation billiard balls, 4 regulation size billiard cues, 1 table brush, 1 triangle, 1 pack of chalk and buffet table top cover.

6. Buffet table top cover:

Use the 4 foam inserts and the vinyl cover to make a buffet table top on your billiard table for entertaining large groups.

Keeping Your Table In Top Condition

- 1.) Always keep your table covered when not in use. Use foam inserts for rain.
- 2.) Clean chalk marks off fabric with a clean wet towel.
- 3.) Keep gum and a cigarette away from table at all times.
- 4.) Clean exterior with mild soap and water - then rinse clean with water.
- 5.) Never use solvents of any kind on fabric or exterior surface.
- 6.) Small scratches on simulated wood surface can be easily removed by sanding using a #400 wet and dry sandpaper then wax or polish the affected area.
- 7.) Move your table safely using a four wheel-furniture dolly under each pedestal.

MURREY OUTDOOR PRODUCTS LIMITED WARRANTY

WARRANTY DURATION: This Murrey products is warranted to the original consumer purchase for a period of 3 years against workmanship defects in the cloth fading and deterioration. 2 years against workmanship defects in the cabinet, It also warrants a period of 90 days against workmanship defects in the nose rubber and pockets from the original purchase.

WARRANTY COVERAGE: ESCALADE SPORTS warrants to the original Consumer Purchaser that any Product of its manufacture is free from defects in material and workmanship when used for the intended purpose under normal use and conditions, only valid when the product is installed and serviced by MURREY or its authorized dealer or agent. Customers must use the vinyl table cover and foam inserts during rain, snow and wet conditions in order to protect the table. THIS WARRANTY IS VOID IF THE PRODUCT HAS BEEN DAMAGED BY ACCIDENT, UNREASONABLE USE, NEGLIGENCE, IMPROPER SERVICE, FAILURE TO FOLLOW INSTRUCTIONS PROVIDED WITH THE PRODUCT OR OTHER CAUSES NOT ARISING OUT OF DEFECTS IN MATERIAL AND WORKMANSHIP.

WARRANTY PERFORMANCE: During the above warranty period, ESCALADE SPORTS shall repair or replace with a comparable model, and/or Product, or component thereof, for any product which may prove defective under normal use and proper care, and which our examination shall disclose to our satisfaction to be thus defective, please contact our Warranty Dept.

1-866-556-2757 / Warranty Dept.

Or Write us at:

Escalade® Sports, Inc. - P. O. Box 889, Evansville, IN 47706 - Attn: Warranty Dept.

Or E-mail us at:

billiardtables@escaladesports.com

Other than shipping requirements no charge will be made for such repair or replacement of in-warranty Products. ESCALADE® SPORTS strongly recommends that the Product is insured for value prior to mailing.

WARRANTY ON SLATE SURFACE

Manufacturer warrants for ten (10) years, Escalade Sports will repair the playing surface of this table, free of charge, if it fails to remain flat, within a tolerance of + or - 30/1000 of an inch, measuring from any flat plane within the playing surface. **NOTE:** Cloth not included in warranty. Should this product become defective due to material or workmanship within period, contact the Customer Service Department. This warranty is not transferable and does not cover normal wear and tear, or damage caused by improper handling, installation or use of this product. This warranty is also void if product is in any way abused, damaged, or modified from its original state, or if used for other than residential use. This warranty gives the consumer specific legal rights, and may have other rights which may vary from state to state.

WARRANTY DISCLAIMERS: ANY IMPLIED WARRANTIES ARISING OUT OF THIS SALE, INCLUDING BUT NOT LIMITED TO THE IMPLIED WARRANTIES OF MERCHANTABILITY AND FITNESS FOR A PARTICULAR PURPOSE, ARE LIMITED IN DURATION TO THE ABOVE WARRANTY PERIOD. ESCALADE® SPORTS SHALL NOT BE LIABLE FOR LOSS OF USE OF THE PRODUCT OR OTHER CONSEQUENTIAL OR INCIDENTAL COSTS, EXPENSES OR DAMAGES INCURRED BY THE CONSUMER OF ANY OTHER USE.

Some states do not allow the exclusion or limitation of implied warranties or consequential or incidental damages, so the above limitations or exclusions may not apply to you.

LEGAL REMEDIES: This warranty gives you specific legal rights and you may also have other rights, which may vary, from state to state.

ESCALADE®
S P O R T S

PO 889 Evansville, In. 47706
www.escaladesports.com