

OWNER'S MANUAL

Table Tennis Table

Patent Pending

Be sure to write your model number and serial number here for future reference. You can find these numbers printed on the bottom of the table.

MODEL # T8266

SERIAL # _____



CAUTION:

READ ASSEMBLY, OPERATING AND SAFETY INSTRUCTIONS CAREFULLY! AT LEAST TWO ADULTS ARE NEEDED TO PUT THIS TABLE TOGETHER!

Thank you for buying our product. We try hard to ensure that our products are of high quality and free of problems, such as manufacturing defects or missing parts. However, if you have any problems with your new product, please **DO NOT RETURN IT TO THE STORE!**

DO NOT RETURN THIS PRODUCT TO THE STORE!

Call us at:

TOLL FREE 1-800-426-1421

(THIS IS A CONSUMER ONLY NUMBER)

Please have this Owner's Manual with you when you call.

Or write us at: CUSTOMER SERVICE DEPT., P.O. Box 889, Evansville, IN 47706

Fax Number: (812) 467-1399.

Or E-mail us at: customerservice@escaladesports.com





Please provide model number and/or part number (not just the key number) of the product and/or part when you call or write. These numbers can be found on the product, packaging, and/or in this Owner's Manual.

TOOLS NEEDED:

Phillips Screwdriver, Two 7/16 Wrenches, One 3/8 Wrench (an adjustable wrench may be substituted for the wrenches), Tape Measure

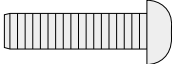
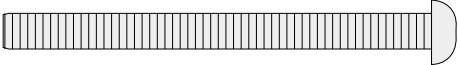
KEY NO.

HARDWARE IDENTIFIER

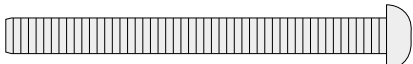
9	1/4-20 x 1-1/2 Hex Hd. Bolt	
10	#10-24 x 3/4 Rd. Hd. Screw	
14	#10-24 x 2-1/4 Rd. Hd. Screw	
15	1/4-20 Locknut	
16	#10-24 Locknut	
17	3/16 S.A.E. Washer	
18	#10-24 x 2 Rd. Hd. Screw	

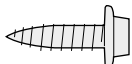
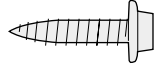
19	#8-32 x 1-1/4 S.M.S.	
20	#8 X 9/16 Sheet Metal Screw	
23	#8 X 5/8 Sheet Metal Screw	

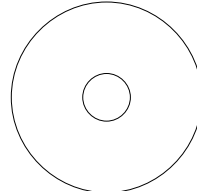
24	Plastic Washer	
----	-------------------	---

2L-6599-02

1. Gently tap a caster socket #12 into each Upright Tube #21 until flange on sockets touches the edge of the tube. **DO NOT HIT CASTER SOCKET TOO HARD WITH A HAMMER!** Sockets may break if hit too hard.
2. Insert casters #11 into caster sockets #12.

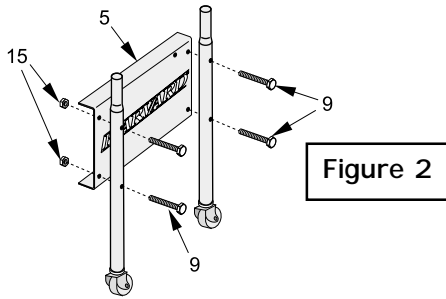
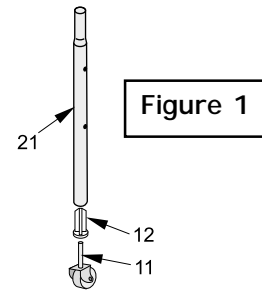

3. Attach two Upright Tube Assemblies to both Name Plates #5, as shown in Figure 2, using four bolts #9 and four nuts #15.

Top View

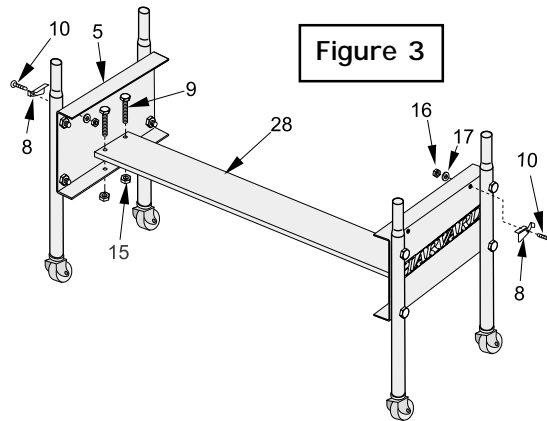
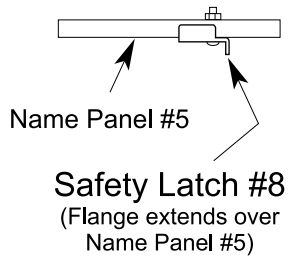

4. Connect the two Name Plate Assemblies to the Bottom Board #28, as shown in Figure 3, using four bolts #9 and four nuts #15.
5. Install a safety latch #8 into the right-hand hole on each name panel as shown in Figure 3. Use one screw #10 one washer #17 and one hex nut #16. **NOTE: Flange on safety latch must extend over top of name panel as shown in Figure 3. Safety latch must pivot freely.**



CAUTION:

INSTALL SAFETY LATCHES #8 AS SHOWN ABOVE FOR PROPER USE OF TABLE! DO NOT SKIP THIS STEP! DO NOT OPERATE TABLE UNTIL SAFETY LATCHES ARE INSTALLED AND ASSEMBLY IS COMPLETE!

Note: Slide U-support back and forth until you see the hole if necessary.

6. Rotate U-support #7 until you see the screw hole in the slot of U-clip # 6. Slide U-support #7 side to side if necessary. See Figure 4.
7. Insert screw #19 through slot in U-clip #6 and into U-support #7. Thread it all the way into U-support #7 until it touches the back of the tube. There should be about 3/8 inch of screw #19 left sticking out.

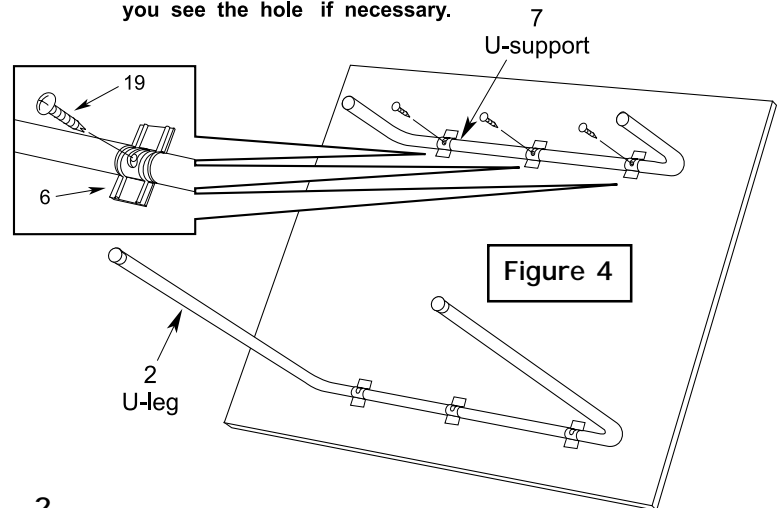

8. Lay table top #1 painted side down, on a smooth, flat surface. Use the shipping container to protect the painted surface of the table top.
9. Attach linkages #4 to **INSIDE** of U-leg #2 as shown in Figure 5. Secure with screws #18, locknuts #16 and plastic washers #24. Tighten hardware snug enough to keep table stable but do not overtighten. Tubes must pivot freely. **NOTE:** Plastic washers go between linkages #4 and U-leg #2.
10. Attach other end of linkages #4 to **OUTSIDE** of U-support #7 with screws #14, locknuts #16 and plastic washers #24. Tighten hardware until snug but do not overtighten. Tubes must pivot freely.

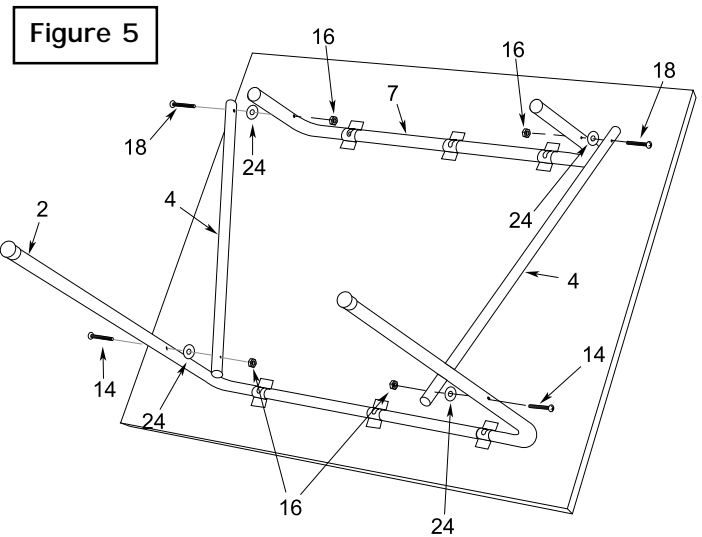

11. Attach four Corner Caps #22 to bottom of table, as shown in Figure 6, using three screws #23 per Corner Cap.

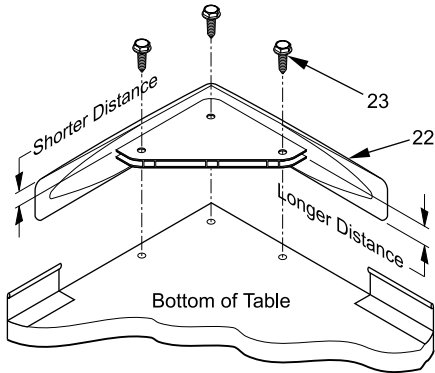

Figure 6

12. Prepare an area for the assembly of the second table top half. If necessary, move the first table top half aside with the aid of a helper. Be sure to place it in a location where it won't be disturbed or damaged. If setting on its side, be sure to place the bottom edge no less than 12 inches away from the wall. Also be sure to place carpet or pieces of the shipping carton down to protect table top edges. If floor is not carpeted, brace table top half with a heavy object to keep it from sliding.
13. Repeat steps 6 thru 12 on second table half.

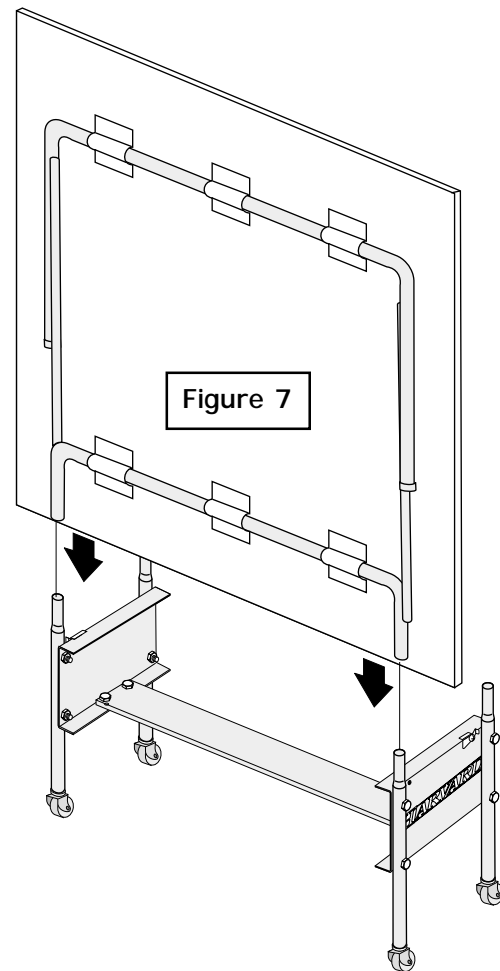

Figure 7

⚠ WARNING:
 AT LEAST TWO (2) ADULTS ARE NEEDED TO COMPLETE THE REST OF THIS ASSEMBLY! WHEN ASSEMBLING TOPS TO BASE, HANDLE TOP ASSEMBLIES BY GRASPING ONLY THE TOPS THEMSELVES. DO NOT GRASP METAL LEGS, U-SUPPORT, LINKAGE, OR HINGES. THESE PARTS CAN MOVE AND COULD PINCH FINGERS OR HANDS CAUSING SERIOUS INJURY! ASSEMBLE AS SHOWN WITH LEGS FULLY CLOSED AND TOPS IN A VERTICAL POSITION. DO NOT OPEN LEGS AND TRY TO ASSEMBLE. TABLE TOPS ARE HEAVY - DO NOT ATTEMPT TO ASSEMBLE ALONE!

14. With two adults, attach table top (#1) to table base, as shown in Figure 7. With at least one adult on each side of table top, lift top and align ends of "U"-support tube with top of upright tubes. Slide tubes together.
15. With two adults, put other table top onto other pivot tubes following instructions in step 2.

⚠ WARNING:
 DO NOT OPEN THE TABLE TO PLAYING POSITION UNTIL BOTH TOPS ARE INSTALLED! DO NOT LEAVE TABLE STANDING UNATTENDED. IT COULD BE KNOCKED OVER CAUSING SERIOUS BODILY INJURY OR PROPERTY DAMAGE.

MELLO OPENING AND CLOSING INSTRUCTIONS YELLO



CAUTION:

READ OPERATING INSTRUCTIONS CAREFULLY BEFORE OPERATING TABLE!
DO NOT ALLOW CHILDREN TO OPEN TABLE! DO NOT CLIMB, STAND OR JUMP ON TABLE! SERIOUS OR FATAL INJURY MAY RESULT! THIS IS NOT A TOY! TABLE IS TO BE OPENED OR CLOSED BY ADULTS ONLY! FAILURE TO COMPLY WITH OPENING AND CLOSING INSTRUCTIONS COULD RESULT IN PERSONAL INJURY OR PROPERTY DAMAGE.

TO OPEN:

1. Stand behind the table near the safety latch.
2. Pull legs out slightly from bottom of table.
3. Hold table half with one hand and pivot safety latch enough to allow the edge of the table half to pass over it.
4. While keeping an eye on the safety latch, pivot table half until it moves past the safety latch. Once edge of table has passed over safety latch, stop pivoting table half.
5. With both hands on the table half, center yourself along the table half and lower the table half to the floor.
6. Repeat for the other table half.

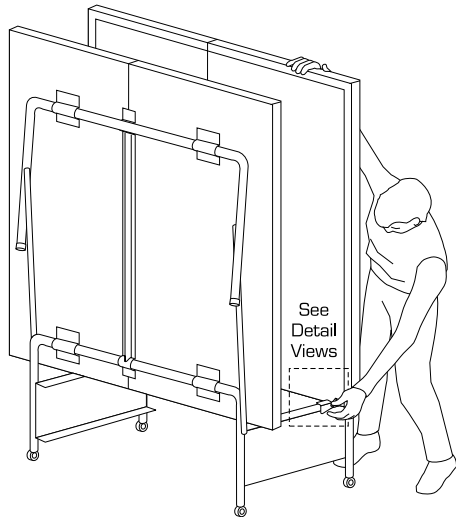

See Detail Views

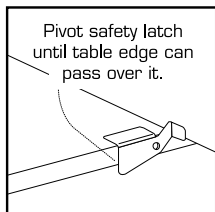

Pivot safety latch until table edge can pass over it.

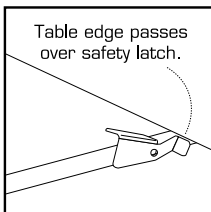
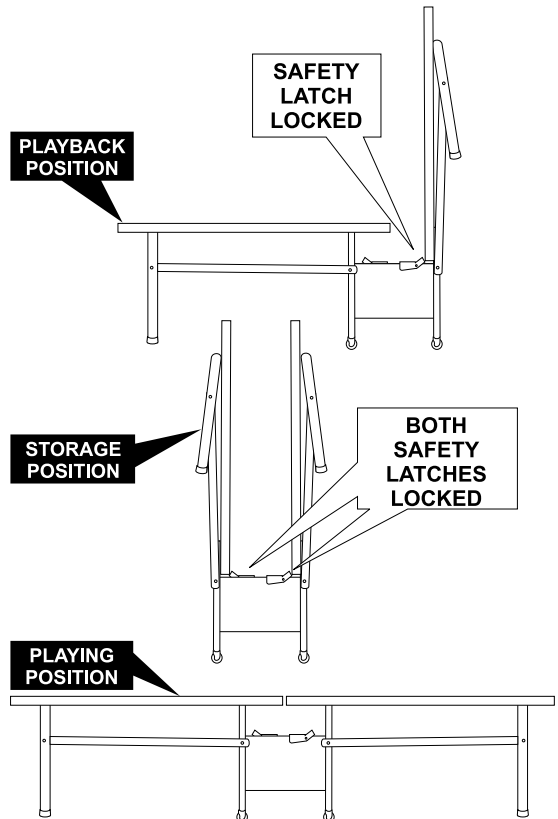

Table edge passes over safety latch.

TO CLOSE:

1. Remove net posts from table.
2. Lift table half upward and inward to vertical position.
3. Check to be sure that table half is locked in the safety latch.
4. Repeat for the other table half.



! WARNING!

DO NOT LIFT TABLE BY THE TABLE TOPS!
TABLE IS NOT FASTENED TO BASE AND CAN COME LOOSE, CAUSING PERSONAL INJURY OR PROPERTY DAMAGE!

IF TRANSPORTATION OTHER THAN ROLLING IS NECESSARY, WITH AT LEAST **THREE ADULTS** DISASSEMBLE TABLE. ONE ON EACH END OF ONE TABLE HALF TO LIFT IT UP AND ONE TO HOLD OTHER TABLE HALF SO TABLE DOES NOT TIP OVER. THEN REMOVE OTHER TABLE HALF. MOVE UNIT IN THREE OR FOUR PIECES AND REASSEMBLE. DO NOT LEAVE TABLE WITH ONE TABLE HALF INSTALLED UNATTENDED.



CARE AND MAINTENANCE

You have purchased a quality product that will give you years of enjoyment. By following these simple maintenance steps, you will add to the life of your new table.

THE TABLE TOP

The top (playing surface) of your table is made of particle board. Like all products made of wood, it can be affected by atmospheric changes in both temperature and humidity. This may cause a slight sag or distortion as the top expands or contracts. This is normal and should not cause concern as it does not detract from the play or utility value of the table. After assembly of the table, you can minimize the effects of temperature and humidity changes by storing the table in the folded up position in a dry area when table is not in use.

STORAGE OF YOUR TABLE

This table must be stored indoors to prevent damage to the playing surface. Dampness and extreme temperature changes can cause the wood to warp, swell, crack or blister. When your table is not in use, it should be folded up in a dry area. Due to the nature of particle board, table top may bow. Damp and humid conditions will amplify this. This is normal and will not affect playability of table.

CLEANING YOUR TABLE

To clean your table use a soft, damp (NOT WET) cloth only. To prevent damage to your table's playing surface, DO NOT USE ANY CHEMICALS, ABRASIVE OR CLEANING PRODUCTS on your table's playing surface.

MAINTENANCE OF YOUR TABLE

Be sure to oil all moving parts of your table including the pivot points. This will insure the safety and ease of use of your table.

This table must be kept indoors to prevent damage to the playing surface. Dampness and extreme temperature changes which occur on patios or similar areas can cause wood to warp, swell, crack or blister.

UNLEVEL FLOORS

If table does not seem level, it is probably due to uneven or unlevel floors. Set the table in its PLAYING POSITION and move table several inches in different directions to find the best location for the table. If the floor is extremely unlevel, table may not play or operate properly. If table is high in the center, shim up under the outer U-legs.

LIMITED WARRANTY

Manufacturer warrants to the original retail purchaser, this product to be free from defects in material and workmanship for a period of ninety (90) days from the date of purchase.

Should this product become defective due to material or workmanship within the warranty period, contact our Customer Service Department for repair or replacement at our option.

This warranty is not transferable and does not cover normal wear and tear, bowing of the table or damage caused by improper handling, installation or use of this product. This warranty is also void if product is in any way abused, damaged, or modified from its original state, or if used for other than residential use.

This warranty gives you specific legal rights, and you may have other rights which vary from state to state.

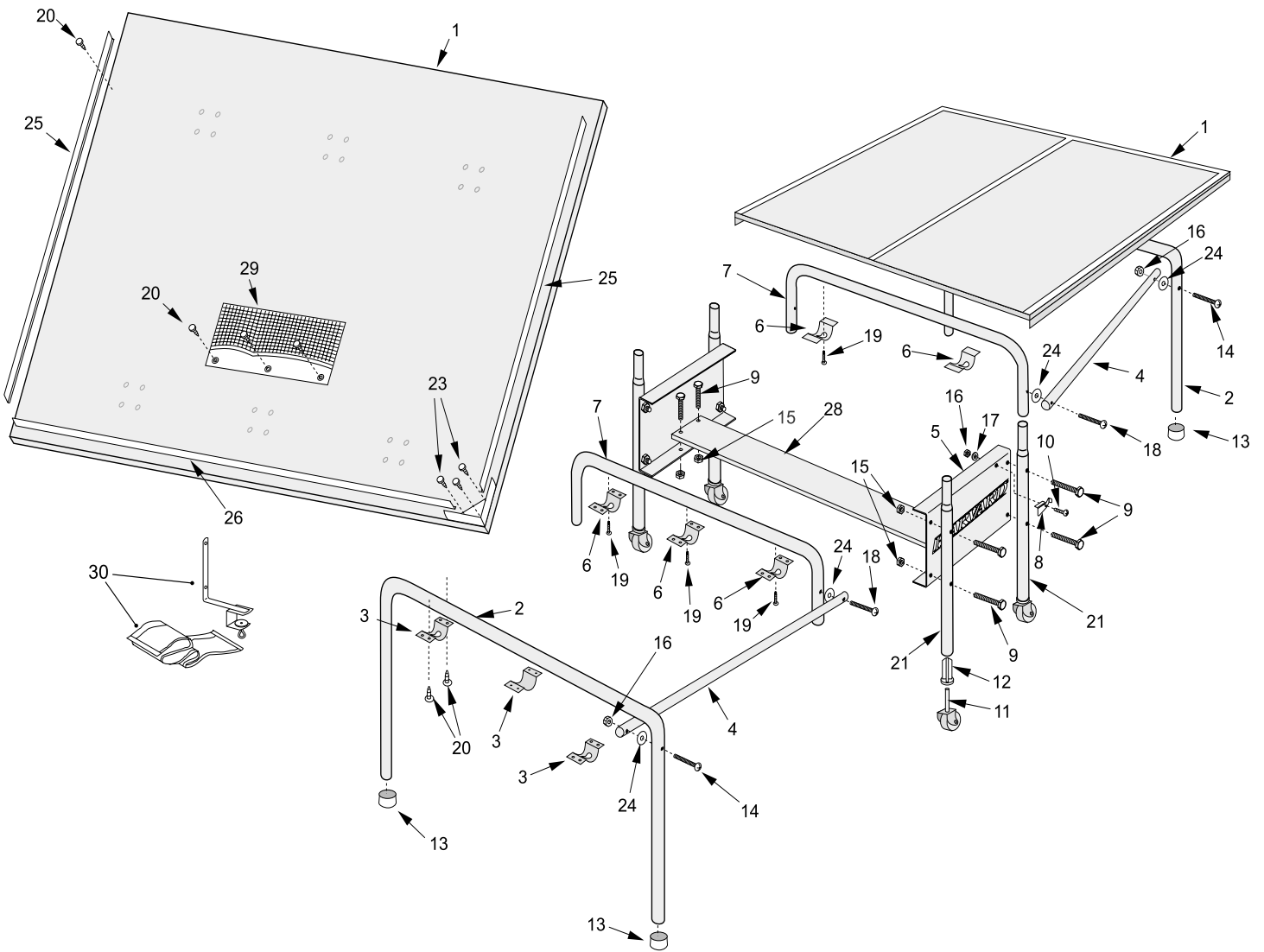

PRODUCT PARTS LIST

Key #	T8266	Description	Qty.	Key #	T8266	Description	Qty.
1	4A-6507-00	5/8" Board	2	16	601-80B	#10-24 Locknut	10
2	8S-6578-04	U-leg	2	17	701-1B	3/16" Flatwasher	2
3	2S-6319-02	1-1/4 U-Clip	6	18	701-186	#10-24 x 2 Phil Rnd Hd Scr	4
4	8S-6325-03	Linkage	4	19	701-141	#8-32 x 1 1/4 Sheet Metal Screw	6
5	2S-6386-00	Name Panel	2	20	701-105	#8 x 9/16 Sheet Metal Screw	84
6	2S-6387-01	U-clip	6	21	8S-6576-03	Upright Tube	4
7	8S-6577-03	U-support	2	22	3M-6494-00	Corner Cap	4
8	2S-6264-03	Safety Latch	2	23	1B-6449-00	#8 x 5/8 Sheet Metal Screw	12
9	701-47	1/4-20 x 1 1/2 Hex Head Bolt	12	24	2B-6087-00	Plastic Washer	8
10	801-120B	#10-24 x 3/4 Phil Rnd Hd Scr	2	25	2S-6385-00	Side Rail	4
11	2Q-6084-00	Caster	4	26	2S-6374-00	End Rail	2
12	3M-6115-00	Caster Socket	4	27	5A-6700-00	Net and Post Kit	1
13	3M-6447-00	Leg Cap	4	28	2W-6269-02	Bottom Board	1
14	701-84	#10-24 x 2-1/4 Phil Rnd Hd Scr	4	29	3M-6495-00	Paddle/Ball Pouch	1
15	701-26	1/4-20 Locknut	12	30	2L-6599-02	Owner's Manual	1